

# Owner's Manual & Safety Instructions

**Save This Manual** Keep this manual for the safety warnings and precautions, assembly, operating, inspection, maintenance and cleaning procedures. Write the product's serial number in the back of the manual near the assembly diagram (or month and year of purchase if product has no number). Keep this manual and the receipt in a safe and dry place for future reference.

201



## 1 HP SUBMERSIBLE SUMP PUMP



**Do not return  
pump to the store.  
Call 1-844-416-9141**

Visit our website at: <http://www.harborfreight.com>  
Email our technical support at: [productsupport@harborfreight.com](mailto:productsupport@harborfreight.com)

**58031**

When unpacking, make sure that the product is intact and undamaged. If any parts are missing or broken, please call 1-888-866-5797 as soon as possible.

Copyright © 2020 by Harbor Freight Tools®. All rights reserved.  
No portion of this manual or any artwork contained herein may be reproduced in any shape or form without the express written consent of Harbor Freight Tools. Diagrams within this manual may not be drawn proportionally. Due to continuing improvements, actual product may differ slightly from the product described herein.  
Tools required for assembly and service may not be included.

### **⚠ WARNING**

Read this material before using this product.  
Failure to do so can result in serious injury.  
**SAVE THIS MANUAL.**

## Before start-up, note the following:

---

The pump must be connected to a GFCI protected plug which has been installed according to regulations. The plug must have a supply voltage of 120 VAC at 60 Hz.

## CAUTION

---

This pump has been evaluated for use with water only.

## ⚠WARNING

**IMPORTANT! For your own safety – before starting to run the pump, please have the following items checked by an expert:**

1. Risk of electric shock – This pump is supplied with a grounding conductor and grounding-type attachment plug. To reduce the risk of electric shock, be certain that it is connected only to a properly grounded, grounding-type receptacle.
2. Risk of electric shock – This pump has not been investigated for use in swimming pool areas.
3. The electrical connections must be protected from moisture.
4. If there is danger of flooding, the electrical connections must be taken to higher ground.
5. Circulation of caustic fluids, as well as the circulation of abrasive materials, must be avoided at all costs.
6. The pump must be protected from frost.
7. The pump must be protected from running dry.
8. Access by children should also be prevented with appropriate measures.
9.  **To prevent death from electric shock, pump must be connected only to a GFCI protected outlet.**
10. Do not use an extension cord with this item.
11. People with pacemakers should consult their physician(s) before use. Electromagnetic fields in close proximity to heart pacemaker could cause pacemaker interference or pacemaker failure.
12. The warnings, precautions, and instructions discussed in this instruction manual cannot cover all possible conditions and situations that may occur. It must be understood by the operator that common sense and caution are factors which cannot be built into this product, but must be supplied by the operator.

## Fluid Type

---

The Pump is designed for use with water with a maximum temperature of 77° F (25°C). Do not use the pump for other fluids, especially not fuels, cleaning fluids, or other chemical products.



## Specifications

<b>Electrical Rating</b>	120 VAC / 60 Hz
<b>Amperage</b>	10A
<b>Power</b>	1 HP
<b>Power Cord Length</b>	8'
<b>Maximum Flow @ 0'</b>	6000 GPH
<b>Maximum Head lift @ 0 Flow</b>	30'
<b>Discharge Port</b>	1-1/2" NPT (1-1/4" NPT with adapter)

## Installation

The submersible motor pump must be installed in a stationary position with either:

- a. A fixed pipeline or
- b. A flexible hose pipe.

## Please note!

1. Do not install the pump by suspending it unsupported from its delivery pipe or power cord. The pump must be suspended from the handle or be placed on the bottom of the basin. To ensure that the pump works properly, keep the bottom of the basin free from sludge and dirt of all kinds.
2. If the water level sinks too low, any sludge in the basin will dry out and stop the pump from starting. To help ensure the pump will start as required, check the pump regularly with start-up tests.

## Power Supply

1. The pump is equipped with a shock-proof plug according to regulations. The pump is designed to be connected to 120 VAC, 60 Hz GFCI protected socket.
2. Make sure that the socket is sufficiently secured and is in excellent condition.
3. When the plug is inserted into the socket, the pump will be on standby.
4.  **WARNING: To prevent death from electric shock, pump must be connected only to a GFCI protected outlet.**

**WARNING! TO PREVENT SERIOUS INJURY:**

If the power cord or plug is damaged, do not use the pump. The power cord or plug may only be repaired by a certified electrician.

## Areas of use

1. This pump is designed to pump water only.
2. This pump is designed to be used for:  
Removing groundwater from basements and crawl spaces.
3. This pump should NOT be used for:  
Continuous run, fountain/pond water features.  
Removing water from swimming pools or spas. Septic or sewage systems.
4. This pump can also be used to transfer water (e.g. household, farming, plumbing).

# Installation Instructions

1. Construct a sump basin that is at least 14" deep and at least 10" in diameter. Clear basin of any debris that could clog pump.
2. Position Pump on solid surface so that both hoses are free from kinks the Float Switch is away from the inlet pipe and at least 1" away from all obstructions throughout its movement.
3. Install discharge plumbing. Insert rigid pipe into the male adapter and screw into place.
4. To prevent excessive cycling from backflow of water, install a check valve (sold separately) onto the discharge pipe. This prevents water from flowing back after the pump shuts off.
5. Fit a sump cover with a hole for the discharge pipe and a hole for the power cords. Thread the Power Cords through their holes, but do not plug them in yet. Set the sump cover aside for now. Place unused end of discharge hose the other end as needed to direct the water discharge at least 3 feet away from the source.

**Note:** The sump cover can also be fitted with a vent pipe, if desired.

**Note:** Wrap all threaded connections with PTFE thread seal tape.

6. Connect additional Discharge Pipe as needed to direct the water discharge at least 3 feet away from the foundation. Slope the discharge pipe downward, away from the foundation. The discharge should be kept as short as possible with a minimum number of turns.

**IMPORTANT:** Do not exceed the Maximum Head Lift @ 0 Flow of the Pump.

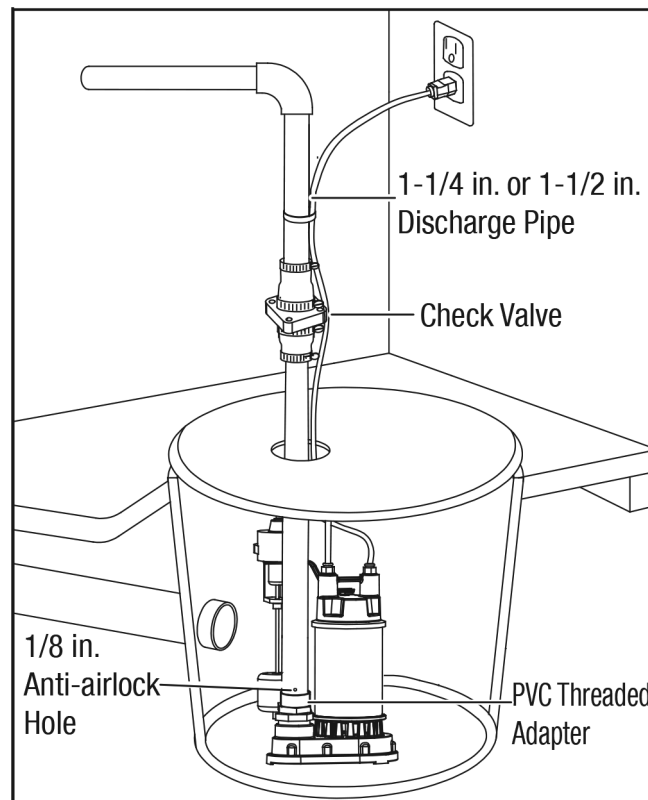

**Figure A: Sump Pump Installation**

## Operation

After reading these instructions, consider the following points before starting the pump:

1. Verify that the pump rests on the floor of the basin.
2. Verify that the discharge pipe is properly connected.
3. Verify that the electrical connection is 120 VAC, 60 Hz.
4. Verify that the electrical socket is GFCI protected and in good condition. Test GFCI protected outlet before use.
5. Verify that water and moisture cannot get near the power supply socket.
6. Verify that the pump is installed so as to prevent running dry.



### **⚠️ WARNING**

**TO PREVENT SERIOUS INJURY FROM ACCIDENTAL OPERATION:**  
Unplug the Pump from its electrical outlet before performing any inspection, maintenance, or cleaning procedures.

If the pump is moved during operation, flush it out with clean water after every use.

## Quarterly Maintenance

---

The below maintenance must be performed at least once every 3 months under optimal conditions. For frequent use, or dirty areas, more frequent maintenance is required.

1. Clean sludge and debris from the bottom of the basin.
2. Clean sludge/debris from inlet screen.
3. Make sure discharge pipe is free from leaks.
4. Make sure check valve is functioning properly.
5. Manually operate flow switch to determine that pump turns on/off as intended.

## Parts List and Diagram

Part	Description	Qty.
1	Pump Cord	1
2	Handle	1
3	Motor	1
4	Shaft	1
5	Impeller	1
6	Gasket	1
7	Volute	1
8	Screw	7
9	Adaptor	1
10	Float Switch	1

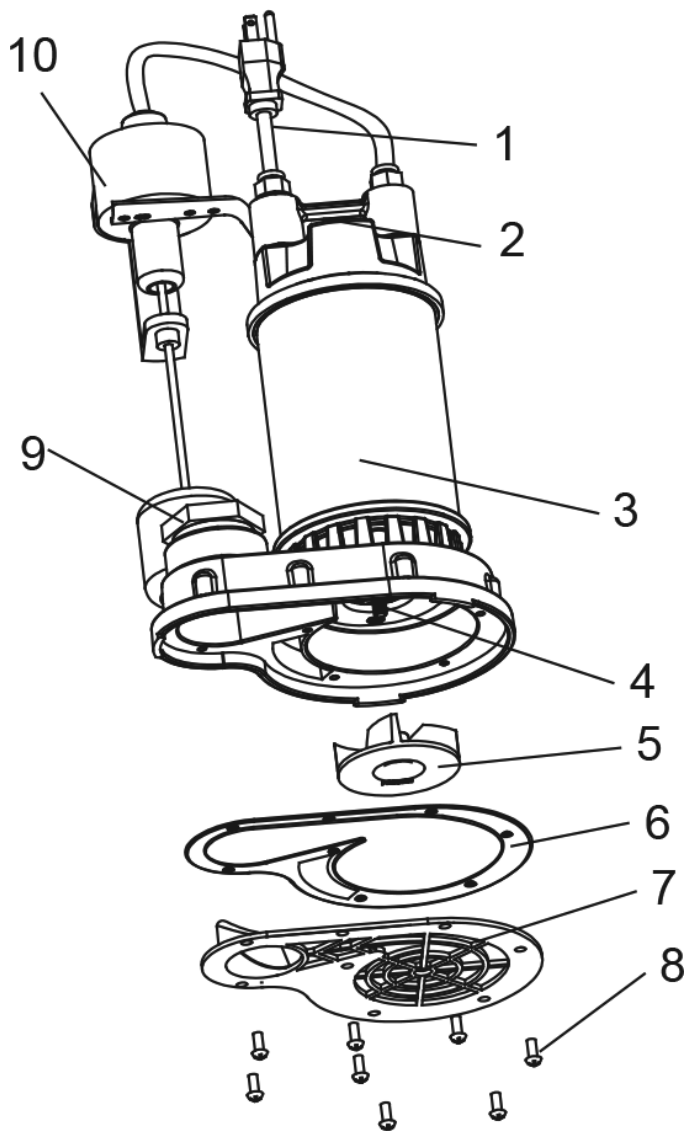

Record Product's Serial Number Here: \_\_\_\_\_

**Note:** If product has no serial number, record month and year of purchase instead.

**Note:** Some parts are listed and shown for illustration purposes only, and are not available individually as replacement parts. Specify UPC 193175430991 when ordering parts.

## Limited 90 Day Warranty

Harbor Freight Tools Co. makes every effort to assure that its products meet high quality and durability standards, and warrants to the original purchaser that this product is free from defects in materials and workmanship for the period of 90 days from the date of purchase. This warranty does not apply to damage due directly or indirectly, to misuse, abuse, negligence or accidents, repairs or alterations outside our facilities, criminal activity, improper installation, normal wear and tear, or to lack of maintenance. We shall in no event be liable for death, injuries to persons or property, or for incidental, contingent, special or consequential damages arising from the use of our product. Some states do not allow the exclusion or limitation of incidental or consequential damages, so the above limitation of exclusion may not apply to you. THIS WARRANTY IS EXPRESSLY IN LIEU OF ALL OTHER WARRANTIES, EXPRESS OR IMPLIED, INCLUDING THE WARRANTIES OF MERCHANTABILITY AND FITNESS.

To take advantage of this warranty, the product or part must be returned to us with transportation charges prepaid. Proof of purchase date and an explanation of the complaint must accompany the merchandise. If our inspection verifies the defect, we will either repair or replace the product at our election or we may elect to refund the purchase price if we cannot readily and quickly provide you with a replacement. We will return repaired products at our expense, but if we determine there is no defect, or that the defect resulted from causes not within the scope of our warranty, then you must bear the cost of returning the product.

This warranty gives you specific legal rights and you may also have other rights which vary from state to state.



26541 Agoura Road • Calabasas, CA 91302 • 1-888-866-5797